

CORNICES AND VALANCES

TABLE OF CONTENTS

CORNICE AND VALANCE FEATURES AND SIZE CONSIDERATIONS

Summary	2
Wood Characteristics	2
Size Considerations	3

CORNICE, VALANCE AND DECORATIVE KEYSTONE OPTIONS

Wood Cornices	4
Decorative Keystones	5
Splice Requirements	5
Fabric-Wrapped Cornice	6-7
Wood Valances	8

GENERAL INFORMATION

Cornice and Valance Return Information	9
How To Measure and Order Cornices and Valances	10
Custom Color	10

PRICE CHARTS AND OPTIONS PRICING

Wood Cornice Pricing	11
Fabric-wrapped Cornice Pricing	11
Decorative Keystone Pricing	11
Custom Color Pricing	11
Wood Valance Pricing	12

Cornice and Valance Features

Cornices and Valances easily lend an impressive touch to windows and doors.

Used on their own or over window treatments, Cornices and Valances are as decorative as they are functional.

- Dress up a drab window
- Enlarge a window
- Conceal headrails or hardware
- Hide imperfections
- Unique characteristics of premium hardwood ensure one-of-a-kind Cornices and Valances
- Custom color option is available for Regal and Noble Cornices
- Decorative keystones add strength and dimension to Regal and Noble Cornices
- Fabric-wrapped Cornices can create a coordinated or contrasting look

Note: Fabric-wrapped Cornices can only be ordered as an outside mount.

WOOD CHARACTERISTICS

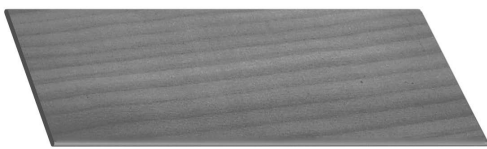

Flat Grain

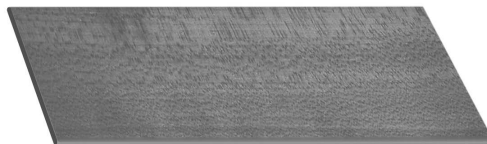

Grain Change

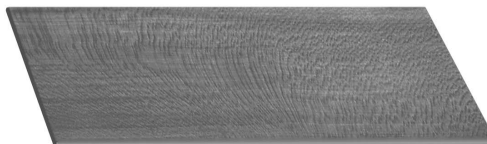

Tiger Stripping

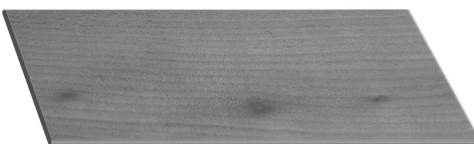

Burl/Bird's Eye

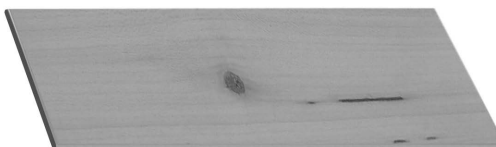

Pin Knots

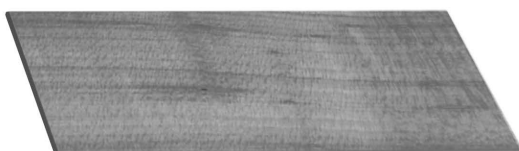

Mineral Marks

Wood used to manufacture Graber wood valances and cornices has many natural characteristics which make it truly unique. The following are all natural characteristics of wood, and we do not consider them to be defects:

Grain	The direction, size and appearance of wood fibers vary greatly depending on where the wood is cut from within the tree.
Burl	Formed from an irregular growth on the outer edge of the tree.
Bird's Eye	Small area on the surface of the board where fibers are contorted to form circular figures that resemble birds' eyes.
Pin Knots	Vary in size, shape, structure and color.
Mineral Marks	Dark or discolored areas caused by minerals which the tree extracts from the water or soil. Can be either a streak or a stain, usually blackish blue.

Please be assured that these markings in no way affect the durability or the structural integrity of the product.

Natural variations in color and grain are inherent in the beauty of wood. These variations are within established industry guidelines and should be expected. When two or more pieces of wood are spliced together to create wider valances or cornices, there may be variations in the dye lot and grain between the sections. In addition, valances and cornices may stain slightly darker or lighter than the samples shown in the sample books and selectors.

Size Considerations

CORNICE AND VALANCE SIZE CONSIDERATIONS

Cornices and valances wider than the widths shown in the column "Maximum Width Without Splicing" will be manufactured in multiple sections. The sections must be assembled during installation. Symphony Cornice cannot be spliced.

Type of Valance or Cornice	Minimum Width		Maximum Width Without Splicing		Maximum Width With Splicing or Keystones	
	Inside Mount	Outside Mount	Inside Mount without returns	Outside Mount	Inside Mount	Outside Mount
4" Classic Wood Valance	8¼"	8"	94"	93 ³ / ₁₆ "	193"	193"
4" Curved Wood Valance			94"	92 ¹ / ₈ "		
4½" Symphony Wood Valance			94"	92 ¹ / ₁₆ "		
4½" Symphony Wood Cornice	8¼"	8"	94"	92½"	94"	92½"
5½" Noble Wood Cornice			94"	92 ¹ / ₈ "	366"	366"
7½" Noble Wood Cornice			94"	91 ⁷ / ₁₆ "		
5½" Regal Wood Cornice			94"	91 ³ / ₁₆ "		
7½" Regal Wood Cornice			94"	90 ¹ / ₁₆ "		

See backside measurements chart below for calculations based on product selected.

Valances

- Outside mount standard with returns
- Inside mount standard without returns

These formulas are used to calculate **BACKSIDE** Valance measurements.

Valance Mount	Blind Types	Valance Profiles	Formula
Inside Mount with No Returns	All Blind Types	All	Ordered width - ¼"
Inside Mount with Returns	All Blind Types except: Natural Drape Sheer Vertical	All	Ordered width + ¾"
	Natural Drape*	All	Ordered width + 1"
	Sheer Vertical*	All	Ordered width + ½"
Outside Mount with No Returns	All Blind Types except: Sheer Vertical	All	Ordered width + ½"
	Sheer Vertical*	All	Ordered width + ¼"
Outside Mount with Returns	All Blind Types except: Natural Drape Sheer Vertical	All	Ordered width + ¾"
	Natural Drape*	All	Ordered width + 1"
	Sheer Vertical*	All	Ordered width + ½"

* Available September 2011.

Cornices

- Outside mount all have returns and dust cover
- Inside mount returns and dust cover not available

These formulas are used to calculate **BACKSIDE** Cornice measurements.

Valance Mount	Blind Types	Cornice Profiles	Formula
Inside Mount with No Returns	All Blind Types	All	Ordered width - ¼"
Inside Mount with Returns	All Blind Types	Not available	
Outside Mount with No Returns	All Blind Types	Not available	
Outside Mount with Returns	All Blind Types except: Natural Drape* Sheer Vertical* Sliding Panels	All	Ordered width + ¾"
	Natural Drape*	All	Ordered width + 1"
	Sheer Vertical* and Sliding Panels	All	Ordered width + ½"

* Available September 2011.

If the product option of **OTHER** is selected during entry, the **BACKSIDE** cornice/valance measurement will be the exact width entered. There will be no additions or deductions taken. Cornice or valance return size must be specified.

Cornice Options

WOOD CORNICES

- Crafted from premium hardwood
- Fine furniture-quality finish
- L-brackets are included for easy installation
- Noble and Regal cornices available in unfinished, custom color and all Traditions® paints and stains
- One side return available – opposite end will be straight cut

- Outside mount has mitered corners, returns and a dust cover to conceal the top of the blind
- Inside mount has straight-cut ends, no returns, no dust cover
- See page 10 for measuring instructions
- **Cornices not available on bay or corner windows**

NOTE: Wood cornice will be shipped separate from blinds. Manufacturer recommends installing blind and cornice at the same time.

Regal Wood – Outside Mount



Regal Wood – Inside Mount

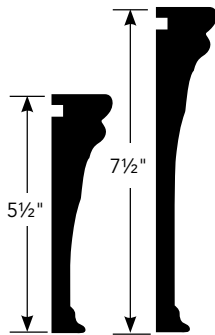

Regal Wood Cornice

The magnificent Regal Wood Cornice, available in either a 5½" or 7½" size and in stained or painted finishes, crowns your blind with style and sophistication.

Noble Wood Cornice

The stately design of the Noble Wood Cornice, available in either a 5½" or 7½" size and in stained or painted finishes, lends an impressive appearance to larger, wider windows.

Noble Wood – Outside Mount

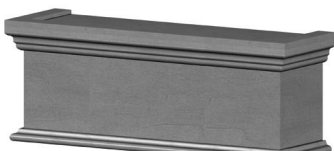

Noble Wood – Inside Mount

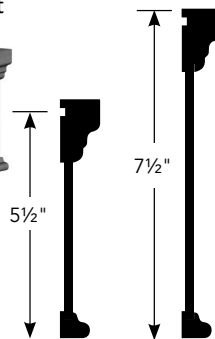

Paint Colors

Almond.....	1724
Angora.....	1052
Antique White.....	1026
Base White.....	1051
Crisp White.....	1712
Custom Paint.....	CUSP
Dover White.....	1683
Ivory.....	1325
Snowflake.....	1603
Stucco.....	1963

Stain Colors

Bridgewood.....	1069	Natural.....	1007
Cappuccino.....	1546	Peru.....	1688
Cherry Wood.....	1014	Pinewood.....	1056
Cognac.....	1465	Raven.....	1690
Custom Stain.....	CUSS	Sable.....	1565
Dark Cherry.....	1316	Saddle Brown.....	1694
Dark Walnut.....	1641	Sienna.....	1685
Espresso.....	1716	Tawny.....	1045
Golden Oak.....	1030	Truffle.....	1054
Honey Maple.....	1013	Unfinished.....	1717
Light Pecan.....	1020	Walnut.....	1012
Mocha.....	1759	Wheat.....	1710

Custom Color: \$75 net surcharge per color, see page 10 for ordering information.

Symphony Wood Cornice

Available in stained or painted finishes to coordinate with most Graber wood blind colors.

Symphony Wood – Outside Mount



Symphony Wood – Inside Mount



Paint Colors

Almond.....	1724
Angora.....	1052
Antique White.....	1026
Base White.....	1051
Crisp White.....	1712
Dover White.....	1683
Ivory.....	1325
Sandblast Angora.....	SB052
Sandblast Base White...SB051	
Sandblast Snowflake...SB603	
Sandblast Stucco.....	SB963
Snowflake.....	1603
Stucco.....	1963

Stain Colors

Bridgewood.....	1069	Peru.....	1688
Cappuccino.....	1546	Pinewood.....	1056
Cherry Wood.....	1014	Raven.....	1690
Cognac.....	1465	Sable.....	1565
Dark Cherry.....	1316	Saddle Brown.....	1694
Dark Walnut.....	1641	Sienna.....	1685
Espresso.....	1716	Tawny.....	1045
Golden Oak.....	1030	Truffle.....	1054
Honey Maple.....	1013	Unfinished.....	1717
Light Pecan.....	1020	Walnut.....	1012
Mocha.....	1759	Wheat.....	1710
Natural.....	1007		

Custom Color: \$75 net surcharge per color, see page 10 for ordering information.

Cornice Options

DECORATIVE KEYSTONES

- Decorative keystones are required on Regal and Noble cornices that require splicing.
- Keystones can also be requested on cornices without a splice
 - Minimum width with a keystone: 12"
 - Maximum number of keystones: 3
- The keystone will be equally spaced
- Keystones will be stained or painted to match the cornice color ordered as standard; optional different color selection available

- Keystone dimensions:
 - 7½" Noble and Regal: 8½" x 9¾"
 - 5½" Noble and Regal: 6¼" x 7¾"

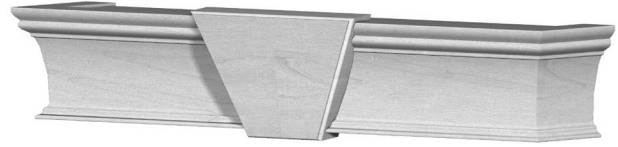

SPLICE REQUIREMENTS

Cornice Profile	Number of Sections	Number of Keystones	No Returns		With Returns (Inside Dimensions)	
			Minimum	Maximum	Minimum	Maximum
5½" Noble Cornice	1	0	8"	94"	8"	82⅞"
	2	1	94⅙"	185⅙"	82⅙"	185⅙"
	3	2	185⅙"	280⅙"	185¼"	278¼"
	4	3	280⅙"	366"	278⅙"	366"
7½" Noble Cornice	1	0	8"	94"	8"	91⅙"
	2	1	94⅙"	186⅙"	91½"	184⅙"
	3	2	186⅙"	279⅙"	184¼"	279⅙"
	4	3	279⅙"	366"	280"	366"
5½" Regal Cornice	1	0	8"	94"	8"	91⅙"
	2	1	94⅙"	186⅙"	91¼"	183⅙"
	3	2	186⅙"	279⅙"	183⅙"	276⅙"
	4	3	279⅙"	366"	276½"	366"
7½" Regal Cornice	1	0	8"	94"	8"	90⅙"
	2	1	94⅙"	186"	90⅙"	182⅙"
	3	2	186⅙"	278⅙"	182⅙"	274⅙"
	4	3	278⅙"	366"	274⅙"	366"

Outside Mount

- Cornices requiring a splice will include keystone (see chart above for details)
- Keystones will be equally spaced as illustrated
- Optional keystones can be ordered with single piece cornices.
- Minimum width with a keystone 12"

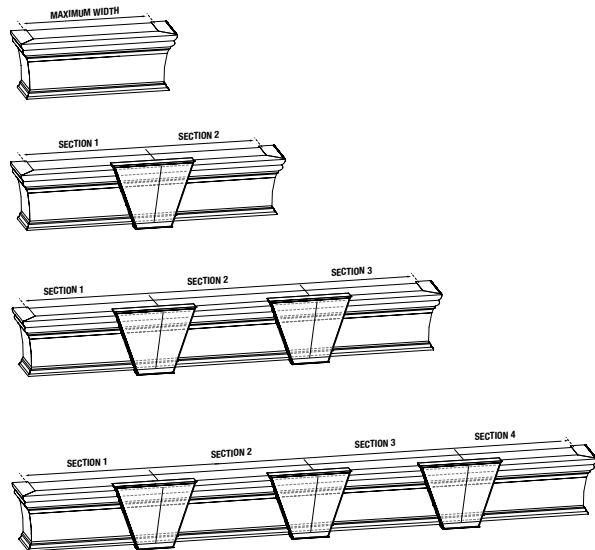

Inside Mount

- Cornices 94" exact or wider require a keystone
- Keystones will be equally spaced as illustrated
- Optional keystones can be ordered with single piece cornices.
- Minimum width with a keystone 12"

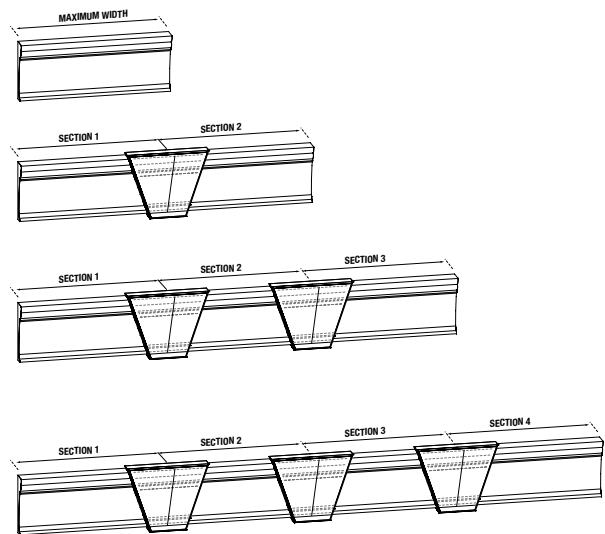

Cornice Options

FABRIC-WRAPPED CORNICE

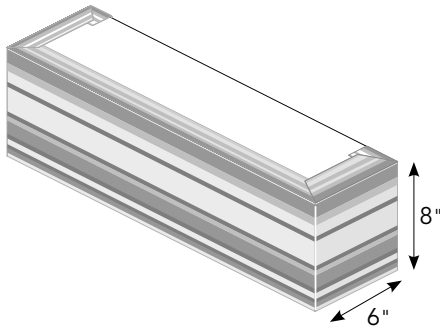

NOTE:
 Back inside measurements:
 Return measures: 5½" depth
 7½" height

To Order a Fabric-wrapped Cornice:

The fabric wrapped cornice will be produced to the inside cornice width (see Top View illustration below). The finished outside measurement of the fabric Cornice will be approximately 3" more than ordered width.

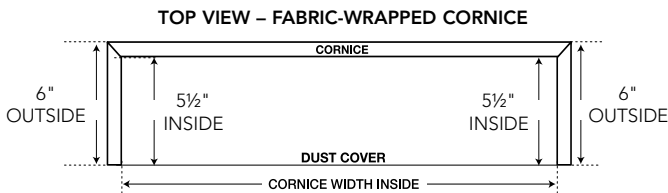

Features

- Available in most fabrics: see below for list
- Create a coordinated statement with your shade or use a bold contrasting fabric
- Outside mount only; 6" returns only (front measurement)
- Polyester batting under the fabric creates an upholstered appearance; a white fabric liner covers the dust cover and inside of the cornice for a finished look
- The Fabric-wrapped Cornice will be produced to the inside cornice width
- The finished outside measurement of the fabric cornice will be approximately 3" more than the ordered width

NOTE: Cornices will be shipped separate from blind. Manufacturer recommends installing blind and cornice at the same time.

Fabric-wrapped Cornice Size Limits	
	Outside Mount
Minimum Size	12"
Maximum Size	117½"

Fabric for all Fabric-wrapped Cornices will be turned width for height. The fabric cornice will run perpendicular to the pattern on Solar, Roller, Roman and Sliding Panel Shades.

Cornice Options

FABRIC-WRAPPED CORNICE FABRICS AND COLORS

Available Fabrics and Colors (see the Graber LightWeaves Solar, Roller, Roman and Sliding Panel Sample Book for fabric swatching)

<p>Acapella*</p> <p>Accent T1245 Dove T1241 Honeybutter T1244 Latte T1243 Mist T1242 Sea T1246 Spa T1247</p> <p>Bamboo ^Δ</p> <p>Bronze T4003 Butter Pecan T4002 Cotton T4005 Toasted Almond T4004</p> <p>Bungalow*</p> <p>Alfalfa T8002 Chamomile T8001 Chestnut T8007 Oatmeal T8003 Oregano T8006 Toasted Almond T8005 Walnut T8004</p> <p>Cambridge LF*</p> <p>Cobblestone T1104 Ivory T1103 Off White T1102 White T1101</p> <p>Cambridge RD*</p> <p>Cobblestone T1204 Ivory T1203 Off White T1202 White T1201</p> <p>Cristalle[†]</p> <p>Angora T3271 Antique White T3274 Parchment T3272 Pristine T3273</p> <p>Crossweave (Roller)*</p> <p>Allspice T1332 Brick T1334 Espresso T1336 Merlot T1333 Mocha T1335 Natural T1331</p> <p>Crossweave (Roman)[†]</p> <p>Beechwood T3410 Cherrywood T3413 Elm T3411 Nutbrown T3412 Sepia T3414</p> <p>Crystalline*</p> <p>Amethyst T1253 Beryl T1251 Selenite T1252</p>	<p>Crystalline Essence*</p> <p>Halite T1262 Indigo T1263 Opal T1261</p> <p>Cumulus^Δ</p> <p>Linen T0506 Melon T0502 Wrought Iron T0504</p> <p>Desert[†]</p> <p>Canyon T3433 Frost T3430 Natural T3434 Sandstone T3432 Shell T3431</p> <p>Fern^Δ</p> <p>Praline Pearl T0201 Russet T0202 Toasted Almond T0203</p> <p>Marquesa^Δ</p> <p>Golden Hazel T1031 Golden Linen T1032 Golden Noir T1030</p> <p>Mission[†]</p> <p>Angora T0602 Antique White T0600 Biscuit T0611 Burgundy T0610 Chamois T0604 Oyster T0612</p> <p>Mystique[†]</p> <p>Burnt Sienna T3282 Claret T3283 Cream Marble T3280 Raw Umber T3284</p> <p>Nautical^Δ</p> <p>Beige T4101 Sand T4102</p> <p>Rain^Δ</p> <p>Butter Pecan T0401 Rattan T0402 Russet T0403 Silver Sage T0405 Taupe T0406</p> <p>Regal[†]</p> <p>Black T3216 Mocha T3215 Sand T3212 Snow White T3210 Vanilla T3211 Wine T3213</p>	<p>Regal Stripe[†]</p> <p>Black T3226 Mocha T3225 Sand T3222 Snow White T3220 Vanilla T3221 Wine T3223</p> <p>Retro Sun^Δ</p> <p>Dusk T1061 Golden Morning T1062</p> <p>Royale[†]</p> <p>Café T3422 Ivory T3420 Sable T3421 Saddle T3423</p> <p>Rujin*</p> <p>Olive Gray T8103 Pine Bark T8104 Russet T8105 Sand T8101 Toasted Almond T8102</p> <p>Sahara[†]</p> <p>Rust T3440 Sierra T3441</p> <p>Savannah[†]</p> <p>Oak T3403 Pistachio T3402 Wheat T3401 Whisper T3400</p> <p>Sedona*</p> <p>Buff T7205 Espresso T7202 Granite T7201 Raven T7204 Soft Moss T7203</p> <p>Sheffield*</p> <p>Chelsea T3101 Henley T3102 Windsor T3103</p> <p>Sonora[†]</p> <p>Creamy Beige T0178 Nutmeg T0173 Toffee T0172</p> <p>Stratus^Δ</p> <p>Bone T4066 Espresso T4062 Flax T4063 Linen T4065</p>	<p>Tango</p> <p>Ash*[†] T3301 Chestnut* T3304 Mahogany*[†] T3302 Whitewash*[†] T3300</p> <p>Tranquil[†]</p> <p>Diamond White T3290 Espresso T3295 Jade T3293 Mushroom T3292 Pearl T3291 Twilight Blue T3294</p> <p>Tranquility^Δ</p> <p>Terracotta T1051 Tiger's Eye T1052 Wheat T1053</p> <p>Versailles[†]</p> <p>Chocolate T3261 French Beige T3264 Pale Almond T3262 Toast T3260</p> <p>Whimsy[†]</p> <p>Aspen T7004 Bronze T7001 Latte T7006 Sand Dune T7005 Stone T7002</p> <p>Wicker^Δ</p> <p>Brownstone T1013 Tawny T1010 Terracotta T1014 Tiger's Eye T1011</p>
---	--	--	---

*Coordinates with Graber Roller Shades

ΔCoordinates with Graber Solar Shades

†Coordinates with Graber Roman Shades

Valance Options

WOOD VALANCES

Features

- Crafted from premium hardwood
- Fine furniture-quality finish
- Inside mount has straight-cut ends, no returns
- Outside mount has mitered corners and returns

- Custom returns may be ordered for both Inside and Outside Mount up to 8", minimum return is ½". See next page for product specific return lengths
- **Not available on Bay or Corner windows**

NOTE: Wood valances will be shipped separate from blind. Manufacturer recommends installing blind and valance at the same time.

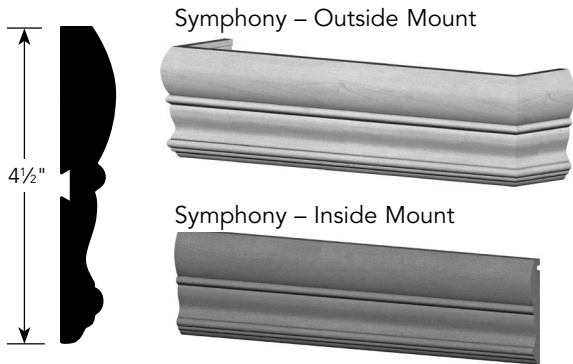

Symphony Wood Valance

The Symphony valance adds a touch of eloquence to any room.

Paint Colors

Almond	1724
Angora	1052
Antique White	1026
Base White	1051
Crisp White	1712
Dover White	1683
Ivory	1325
Sandblast Angora	SB052
Sandblast Base White	SB051
Sandblast Snowflake	SB603
Sandblast Stucco	SB963
Snowflake	1603
Stucco	1963

Stain Colors

Bridgewood	1069
Cappuccino	1546
Cherry Wood	1014
Cognac	1465
Dark Cherry	1316
Dark Walnut	1641
Espresso	1716
Golden Oak	1030
Honey Maple	1013
Light Pecan	1020
Mocha	1759
Natural	1007
Peru	1688
Pinewood	1056
Raven	1690
Sable	1565
Saddle Brown	1694
Sienna	1685
Tawny	1045
Truffle	1054
Unfinished	1717
Walnut	1012
Wheat	1710

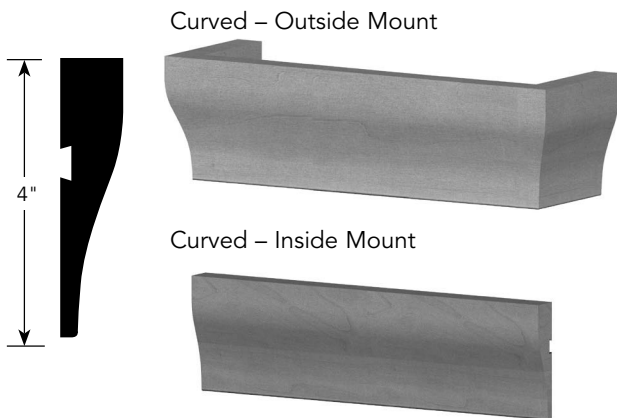

Curved Wood Valance

Featuring gently curved contours, the 4" Curved Wood Valance brings a fresh look to either casual or elegant decors.

Paint and Stain Colors

Dark Cherry	1316
Dover White	1683
Honey Maple	1013
Natural	1007
Snowflake	1603

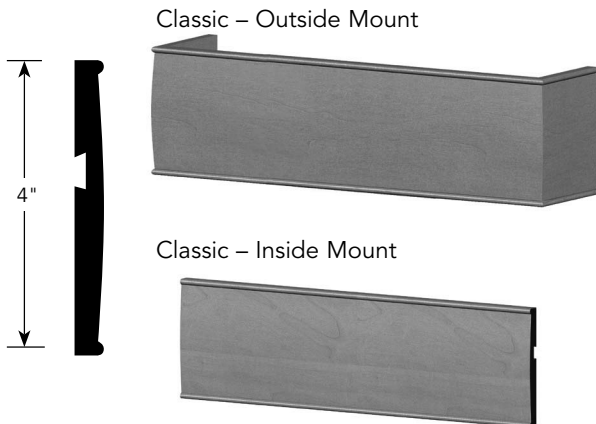

Classic Wood Valance

With its simple styling and beautiful stain or paint finishes, the 4" Classic Wood Valance is perfect for any design style.

Paint and Stain Colors

Dark Cherry	1316
Dover White	1683
Honey Maple	1013
Natural	1007
Snowflake	1603

General Information

CORNICE AND VALANCE RETURN INFORMATION

Product and Valance Type	Standard Return Inside Width	Full Recess Depth	Product and Cornice Type	Standard Return Inside Width	Full Recess Depth		
Vertical Blinds							
4" Classic Wood Valance	5½"	5 ¹⁵ / ₁₆ "	4½" Symphony Wood Cornice	5½"	6¼"		
4" Curved Wood Valance	5½"	6 ¹ / ₁₆ "	5½" Noble Wood Cornice	5½"	6½"		
4½" Symphony Wood Valance	5½"	6¼"	7½" Noble Wood Cornice	5½"	6 ¹³ / ₁₆ "		
			5½" Regal Wood Cornice	5½"	6 ¹⁵ / ₁₆ "		
			7½" Regal Wood Cornice	5½"	7½"		
Roman, Pleated, Cellular and Solar/Roller Shades							
4" Classic Wood Valance*	3¾"	4 ³ / ₁₆ "	4½" Symphony Wood Cornice*	3¾"	4½"		
4" Curved Wood Valance*	3¾"	4 ¹¹ / ₁₆ "	5½" Noble Wood Cornice*	3¾"	4¾"		
4½" Symphony Wood Valance*	3¾"	4½"	7½" Noble Wood Cornice	3¾"	5 ¹ / ₁₆ "		
			5½" Regal Wood Cornice*	3¾"	5 ³ / ₁₆ "		
			7½" Regal Wood Cornice	3¾"	5¾"		
Natural Shades							
4" Classic Wood Valance	3 ⁵ / ₈ "	4 ¹ / ₁₆ "	4½" Symphony Wood Cornice	3 ⁵ / ₈ "	4 ³ / ₈ "		
4" Curved Wood Valance	3 ⁵ / ₈ "	4 ⁹ / ₁₆ "	5½" Noble Wood Cornice	3 ⁵ / ₈ "	4 ⁵ / ₈ "		
4½" Symphony Wood Valance	3 ⁵ / ₈ "	4 ³ / ₈ "	7½" Noble Wood Cornice	3 ⁵ / ₈ "	4 ¹⁵ / ₁₆ "		
			5½" Regal Wood Cornice	3 ⁵ / ₈ "	5 ¹ / ₁₆ "		
			7½" Regal Wood Cornice	3 ⁵ / ₈ "	5 ⁵ / ₈ "		
Slide-View™							
4" Classic Wood Valance	3 ¹ / ₈ "	3 ⁹ / ₁₆ "	4½" Symphony Wood Cornice	3 ¹ / ₈ "	4 ⁷ / ₈ "		
4" Curved Wood Valance	3 ¹ / ₈ "	4 ¹ / ₁₆ "	5½" Noble Wood Cornice	3 ¹ / ₈ "	4 ¹ / ₈ "		
4½" Symphony Wood Valance	3 ¹ / ₈ "	3 ⁷ / ₈ "	7½" Noble Wood Cornice	3 ¹ / ₈ "	4 ⁷ / ₁₆ "		
			5½" Regal Wood Cornice	3 ¹ / ₈ "	4 ⁹ / ₁₆ "		
			7½" Regal Wood Cornice	3 ¹ / ₈ "	5 ¹ / ₈ "		
2" Horizontal Blinds (Wood, Faux, Composite, Aluminum and Vinyl)							
4" Classic Wood Valance	Cord	Wand	Cord	Wand	4½" Symphony Wood Cornice	5"	5¾"
	2 ⁷ / ₈ "	3 ⁹ / ₁₆ "	3 ⁹ / ₁₆ "	4"	5½" Noble Wood Cornice	5"	5 ¹⁵ / ₁₆ "
4" Curved Wood Valance	2 ⁷ / ₈ "	3 ⁹ / ₁₆ "	3 ¹³ / ₁₆ "	4½"	7½" Noble Wood Cornice	5"	6 ⁵ / ₁₆ "
4½" Symphony Wood Valance	2 ⁷ / ₈ "	3 ⁹ / ₁₆ "	3 ⁵ / ₈ "	4 ⁵ / ₁₆ "	5½" Regal Wood Cornice	5"	6 ⁷ / ₁₆ "
					7½" Regal Wood Cornice	5"	7"
2³/₈" & 2½" Horizontal Blinds (Wood, Faux and Composite)							
4" Classic Wood Valance	3¾"	4 ³ / ₁₆ "	4½" Symphony Wood Cornice	5"	5¾"		
4" Curved Wood Valance	3¾"	4 ¹¹ / ₁₆ "	5½" Noble Wood Cornice	5"	5 ¹⁵ / ₁₆ "		
4½" Symphony Wood Valance	3¾"	4½"	7½" Noble Wood Cornice	5"	6 ⁵ / ₁₆ "		
			5½" Regal Wood Cornice	5"	6 ⁷ / ₁₆ "		
			7½" Regal Wood Cornice	5"	7"		
Sliding Panels							
4" Classic Wood Valance	5"	5 ⁷ / ₁₆ "	4½" Symphony Wood Cornice	5"	5¾"		
4" Curved Wood Valance	5"	5 ¹⁵ / ₁₆ "	5½" Noble Wood Cornice	5"	5 ¹⁵ / ₁₆ "		
4½" Symphony Wood Valance	5"	5¾"	7½" Noble Wood Cornice	5"	6 ⁵ / ₁₆ "		
			5½" Regal Wood Cornice	5"	6 ⁷ / ₁₆ "		
			7½" Regal Wood Cornice	5"	7"		

Minimum return length is ½".

Maximum return length is 8".

*Not available with Dual Shades.

NOTE: If the cornice is to be used alone (no product type selected), the return length must be specified at the time of the order.

General Information

HOW TO MEASURE AND ORDER CORNICES AND VALANCES

TOP VIEW: VALANCE

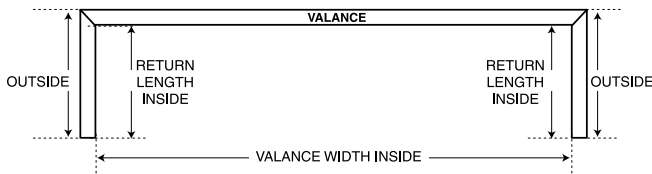

SIDE VIEW: VALANCE

1. Full recess is from front of valance to wall.
2. Return length is from miter to wall.
3. Partial recess: subtract actual window recess from return length to arrive at exact return length.

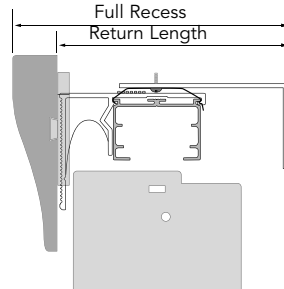

NOTE: Valances and cornices with returns are measured and cut from the **INSIDE** of the miter to ensure the most accurate fit when installed over the headrail or window frame.

TOP VIEW: CORNICE

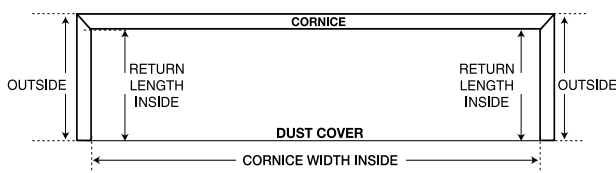

SIDE VIEW: CORNICE

1. Full recess is from front of cornice to wall.
2. Return length is from miter to wall.

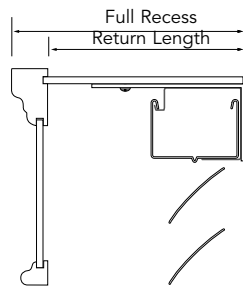

Wood cornices and valances are optional with your custom order or as a stand alone order.

OUTSIDE MOUNT cornices and valances are supplied with returns sized to cover the end of the blind back to the mounting surface. Custom returns may be ordered up to 8".

Minimum return length is 1/2".

Maximum return length is 8".

OUTSIDE MOUNT cornices include a dust cover to conceal the top of the blind.

For blinds ordered as an **INSIDE MOUNT**, valances and cornices are supplied without returns and look best when the blind and valance or cornice can be completely recessed. Ends of the valance and cornice are straight cut. Returns **ARE** available for valance on inside mount blinds that are not completely recessed (must be requested at time of order).

INSIDE MOUNT cornices do **NOT** have a dust cover and returns are **NOT** available.

Additional ordering information:

- Please state at the time of order if the valance or cornice return measurements are for the **EXACT** size required so that no additions or deductions are made
- Valance and cornices will be shipped separate from blind or shade orders
- Manufacturer recommends installing blind or shade and valance/cornice at the same time

NOTE: If mounting over a horizontal product, the blind must be installed first as you will not be able to open the doors on the end brackets to insert the blind.

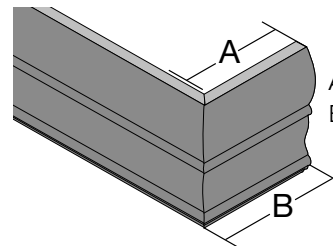

CUSTOM COLOR

Graber offers the unique option of custom color either paint or stain for Regal or Noble cornices. Use the following guidelines when placing your order:

1. Complete the Custom Color Match request form. Forms can be found on SWFconnect.com or graberdirect.com.
2. Supply Springs Window Fashions with a color sample labeled with the color name and purchase order number. The sample needs to be at least 2" x 2". For best results, submit a 3" x 3" color sample.
3. Send the order, along with the request form and color sample to:
 Springs Window Fashions
 ATTN: Graber Custom Color
 33 West 3rd Street, Suite 400
 Williamsport, PA 17701

4. Approval of the custom color sample is required on orders of six or more cornices. A sample of the custom color will be sent upon request for orders of less than six cornices. If a custom color sample is not requested, the sample provided will be used to manufacture the wood cornices. If the color sample is to be returned, please note this on your order.
5. Custom color samples will be sent for approval approximately two weeks after receiving the original color sample.
6. Once approval is received, fabrication of the custom color cornices will begin.

Price Charts

WOOD CORNICE PRICING (Minimum width 8" exact)

Width Up To →	23"	30"	36"	42"	48"	54"	60"	66"	72"	78"	84"	90"	96"	106"
5½" Regal Wood Cornice	\$229	243	251	270	288	307	329	343	354	367	402	407	612	631
7½" Regal Wood Cornice	293	310	321	336	352	367	380	397	406	428	459	492	731	757
5½" Noble Wood Cornice	191	206	217	232	251	270	293	305	314	324	347	352	556	572
7½" Noble Wood Cornice	272	291	303	315	326	340	354	367	378	406	444	477	716	738

Width Up To →	116"	126"	136"	146"	156"	166"	176"	186"	192"	216"	240"	264"	283"	312"	336"	366"
5½" Regal Wood Cornice	\$650	669	688	707	726	745	764	783	1002	1021	1059	1097	1135	1373	1411	1449
7½" Regal Wood Cornice	783	809	835	861	887	913	939	965	1199	1225	1277	1329	1381	1641	1693	1745
5½" Noble Wood Cornice	588	603	619	634	650	666	681	697	912	927	959	990	1021	1251	1283	1314
7½" Noble Wood Cornice	761	783	806	829	851	874	896	919	1149	1172	1217	1262	1307	1560	1605	1650

Custom Color available with Regal and Noble: \$250 surcharge per color

Width Up To →	23"	30"	36"	42"	48"	54"	60"	66"	72"	78"	84"	90"	94"
4½" Symphony Wood Cornice	\$182	196	205	215	234	251	274	281	288	298	319	322	328

*Maximum width 94" (inside mount) and 92½" (outside mount).

FABRIC-WRAPPED CORNICE PRICING

Width Up To →	23"	30"	36"	42"	48"	54"	60"	66"	72"	78"	84"	90"	96"	Add 10"
Fabric-wrapped Cornice	\$368	390	434	455	476	497	515	536	557	578	777	786	795	25

DECORATIVE KEYSTONE PRICING

- Surcharge—7½" Noble and Regal: **\$208** each when requested without a splice
5½" Noble and Regal: **\$199** each when requested without a splice
Maximum keystones on single piece cornice is three (3).

CUSTOM COLOR PRICING

- Surcharge—\$250 per color.

Price Charts

WOOD VALANCE PRICING (Minimum width 8" exact)

Width Up To →	23"	30"	36"	42"	48"	54"	60"	66"	72"	78"	84"
4" Curved Wood Valance	\$76	92	97	104	118	120	128	139	146	158	177
4" Classic Wood Valance	69	81	87	92	104	109	114	125	130	142	156

Width Up To →	90"	96"	106"	116"	126"	136"	146"	156"	166"	176"	186"	193"
4" Curved Wood Valance	\$184	189	208	227	246	265	284	303	322	341	361	380
4" Classic Wood Valance	163	168	185	203	220	237	255	272	289	307	324	341

Width Up To →	24"	32"	36"	42"	48"	54"	60"	66"	72"	78"	84"	90"
4½" Symphony Valance Wood	\$40	45	53	57	61	67	71	75	79	85	87	92

Width Up To →	96"	106"	116"	126"	136"	146"	156"	166"	176"	186"	193"
4½" Symphony Valance Wood	\$100	110	120	130	140	150	160	170	180	190	200

Minimum width 8" exact. Maximum width 193".



Graber is a brand of Springs Window Fashions, the Best Experience Company

